



QR srl - Via Silvestrini, 20 - 37135 Verona Italy  
Tel. +39 045 8202727 - 045 583500  
info@newtom.it www.newtom.it

Cone Beam 3D Imaging  
**NewTom**  
what's next

## FIRST IN CONE BEAM, ACCURATE IN RESULTS.

Latest-generation  
technology

Eco mode for low-exposure  
scans

Patented innovations

Wide FOV range

Maximum  
image quality

Versatile, user-friendly  
NNT software

Accurate treatment  
planning

Outstanding  
patient comfort

## THE GLOBAL MARKET LEADER.



### Pioneers of Cone Beam technology in dentistry

The NewTom team was the first to apply Cone Beam technology in the dental field. The first such device was installed back in 1996: this was the NewTom 9000 (also known as the Maxiscan), the forerunner of the Cone Beam devices that would later be used in the dental X-ray field. Today, thanks to more than twenty years of research and development, NewTom has an efficient international distribution network and is widely acknowledged for its excellence and quality.



An ultra-modern, ultra-technological, ultra-competitive device has been developed from the engineering evolution of the NewTom range. The most complete CBCT.

## Compact design

Modern ergonomics provides maximum technology within a compact space.

## Extended diagnostics

A simple single-scan examination of an anatomical region as large as 24x19 cm allows investigation of the entire maxillofacial area for aesthetic/functional orthognathic surgery and orthodontic treatment purposes.

## Comfort and performance

The latest-generation head support unit provides simple, reassuring patient positioning and excellent image quality.

## Eco Mode

As an offshoot of over twenty years of NewTom experience, Eco Scan protects the health of patients and medical staff alike.

## User-friendly display

The control panel simplifies and speeds up workflows via a clear, easy-to-understand display.

## Maximum versatility

Volumetric examination, Panoramic, Teleradiography and Serial X-rays. All on just one device.



# EVO: COMFORT AND PERFORMANCE

## Cutting-edge efficiency

Maximum patient stability due to the development of a chinrest that allows fast access and natural positioning. Outstanding structural ergonomics guide the user effortlessly and ensure good outcomes from the very first examination.

During the procedure, three lasers trace the reference lines for the area of interest. A mirror in front of the chinrest gives an all-round view of the patient, letting users check for correct positioning and maintain patient-reassuring eye contact.

Correct positioning can be checked at the next stage before proceeding with scanning via the use of two scout images (later-lateral and antero-posterior). These two images allow perfect alignment.



## Enhanced dentist-patient communication

The excellent detail provided by the scans leads to more accurate diagnosis and more complete treatment planning. This information has a highly positive impact on communication between dentist and patient, with the latter gaining a clearer understanding of the treatment and a heightened sense of reassurance.



## Intuitive functions

The new control panel with info display simplifies machine movement and patient positioning. The chinrest can be shifted on the x, y and z axes with ease. To facilitate access to the scan area, the gantry can be moved and height-adjusted via the control panel. The positioning lasers are then activated via the relative key.



# CBCT: EVOLVING INNOVATION



## A REVOLUTIONARY IMAGE CHAIN

NewTom VGi evo introduces a new image chain consisting of elements that boost standard CBCT performance:

- A larger, better-performing sensor (flat panel) allows investigation of volumes of up to 24x19 cm with an improved signal/noise ratio; ;
- A rotating-anode generator with a focal spot of 0.3 mm, suitable for low-exposure high-definition protocols, for post-operative checks and follow-ups.

This provides extremely high quality 1:1 scale images. These are of outstanding utility to specialists, who can then process the data by selecting the voxel as per individual requirements. In addition to these characteristics, users also benefit from faster examination and data transmission, allowing analysis of results in record time



Single 360° rotation to acquire the entire cylindrical volume.



Powerful software allows processing of various image types as well as the tracing and measuring of anatomical structures. Images can easily be shared via third-party software and used on CAD/CAM systems.



Utilization of pulsed emissions means that the X-ray source is only activated when necessary, with standard examination ray emission lasting just 1.2 seconds.



Specialists can count on a high-quality dental-maxillofacial dataset made up of axial, coronal, sagittal and 3D images for comprehensive in-depth analysis of anatomical structures.



Thanks to the acquirable volume sizes and the available scan modes, examinations can be adapted to the requirements of the specific clinical application.



To maximize the profitability of the clinic, the specialist can use the SHARP 2D protocol and obtain a complete 2D set of Panoramic and Teleradiography (AP, PA and LL) images.



SafeBeam™ technology automatically adapts exposure according to the patient's build, eliminating any risk of overestimated dosages.



The high accuracy provided by Cone Beam 3D technology is equally useful when carrying out examinations for implantology, periodontic, maxillofacial and ENT purposes.

# 3D: EXTENDED DIAGNOSTICS



Thanks to 51 different examination modes, the NewTom VGi evo provides specialists with a highly-effective tool that adapts to the specific needs of different clinical applications. The various fields of view on the device define the extent of the anatomical region to be displayed. The FOV range, ideally suitable for the investigation of several different anatomic regions, is regulated by international standards according to the ALARA (As Low As Reasonably Achievable) principle, which aims to minimize the dosage effectively absorbed by the patient.

## ECO

The new Eco Scan mode, available with all FOV, enables dentists to carry out low-exposure patient examinations.

## HIRES

Using HiRes mode with the smallest FOV provides pin-sharp images of localized anatomical zones and the level of detail and definition on the resulting 3D images allows for thorough examination and proper treatment planning.

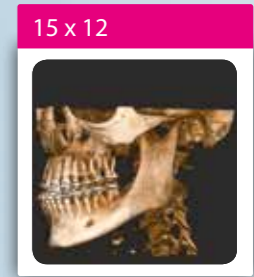
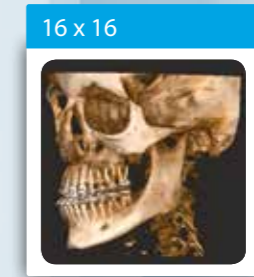
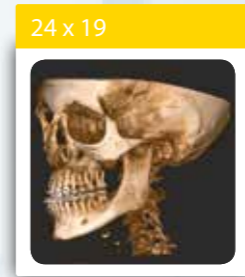
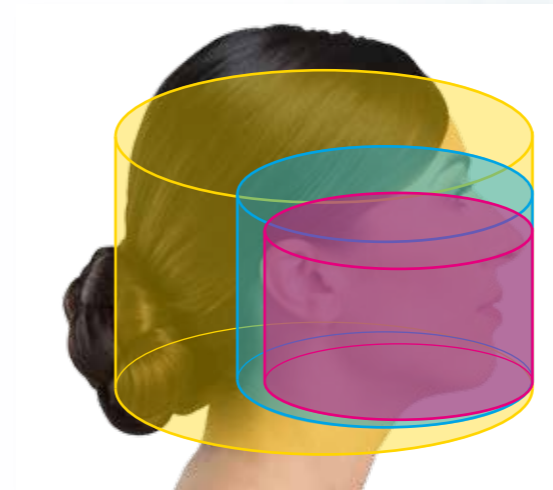

Larger FOV allow for visualization of all the maxillofacial anatomical regions with a single scan. These fields of view are extremely suitable for use in orthodontics, orthognathic surgery and maxillofacial surgery.

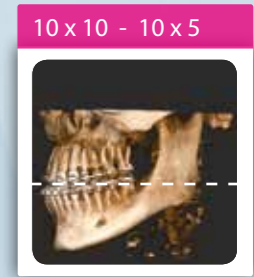
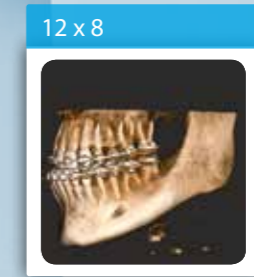
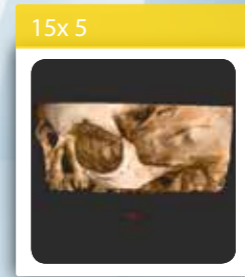
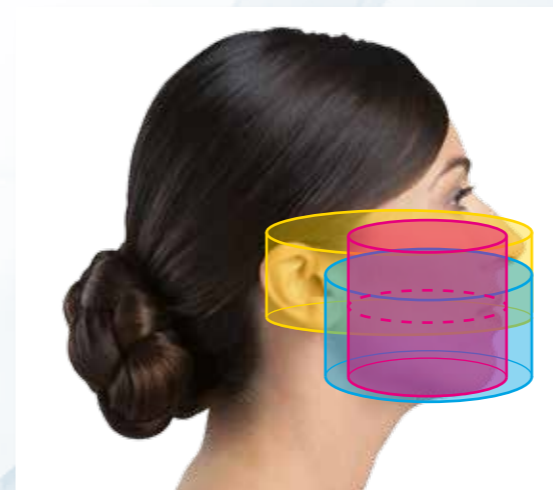

Medium-sized FOV are indicated for ENT (otorhinolaryngology) and TMJ (Temporomandibular Joint) work or full dentition examination and implant planning.

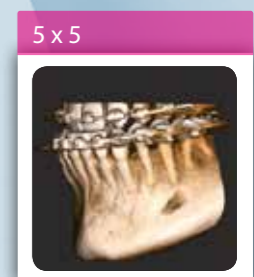
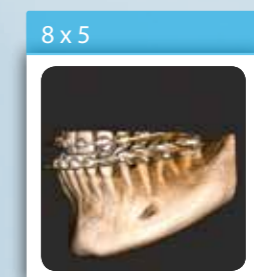
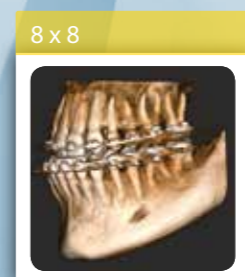

Use of small FOV is indicated for ENT, periodontic and implantology examinations on specific user-selected regions. Smaller areas raise the level of detail and resolution drastically, making images ideal for the diagnosis of all those pathologies where identification of even the smallest details is a must.

# 2D: MULTI-PURPOSE IMAGING

## SHARP 2D

NewTom VGi evo, because of the development of innovative low-exposure technology, allows dentists to obtain a complete set of highly detailed 2D images. These are useful in pre-treatment diagnostic screening or can be used to execute post-operative checks by using all the tools provided by the NNT software.

### Panoramic examination

SHARP 2D function provides a panoramic that also makes peripheral anatomic structures visible. Moreover, the function uses the same magnification and orthogonality ratios applied on conventional panoramic images and, therefore, the same diagnostic assessment parameters.



### Cephalometric examination

In addition to panoramic images, the innovative SHARP 2D function permits Latero-Lateral and Antero-Posterior Teleradiography as an alternative to conventional imaging, highly useful when executing cephalometric examinations.

Using a single low-exposure scan to make three distinct examinations speeds up work and ensures patient exposure levels comparable to those on a 2D digital examination.



# NNT: THE TECHNOLOGICAL CORE

## 2D and 3D analysis software

NNT, designed entirely by NewTom engineers, provides precise information on patient anatomy for various clinical applications and considerably simplifies surgery workflows.

NNT provides different application modes specifically intended for implantology, endodontics, periodontics, maxillofacial surgery and X-ray specialists.

The software features a dedicated implant planning application; this can be used to measure the anatomic region (distances and angles) and trace the nerve, making treatment planning safer and more precise.

It is also possible to use CBCT-obtained images to assess bone density (on the Hounsfield scale).

Just a few simple steps and specialists can process the data acquired during the scan to create a vast array of images.

These can subsequently be saved in a report or distributed with the Viewer version of the software.

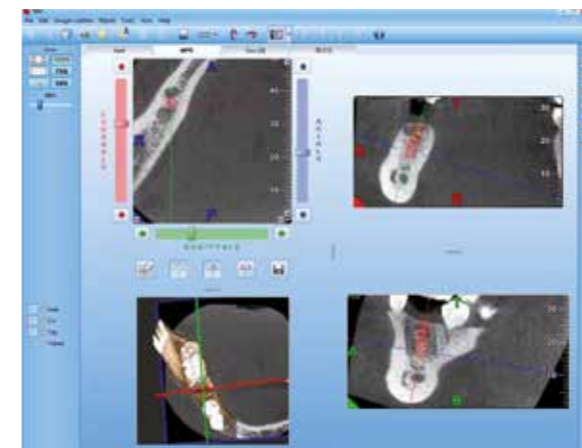
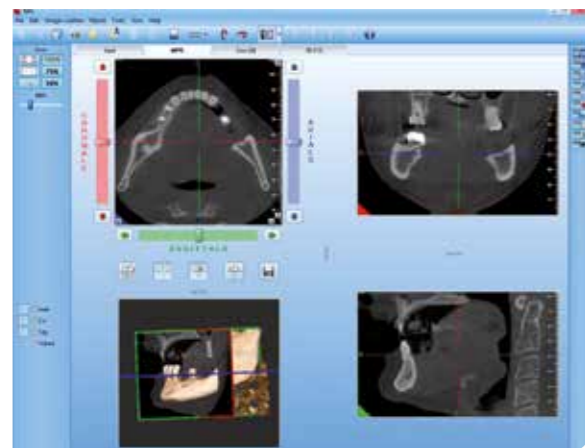

## NNT SOFTWARE COMPATIBILITY



NewTom images are compatible with most of the third-party software on the market and with guided implant, orthodontic simulation and maxillofacial surgery programs. Images can be saved in DICOM 3.0 format. Different software applications permit lifelike overlays to be superimposed on scan-obtained images. This creates a host of options that enhance accuracy in diagnosis, treatment planning and pre-surgical analyses while aiding patient understanding.



# NIP: PERFECT FOR IMPLANT WORK

## NewTom Implant Planning

NewTom Implant Planning is a software package that allows 3D implant simulation. This software can simulate positioning of an implant on 2D and 3D models, identifying the mandibular canal, producing panoramics and cross sections on bone models. Moreover, it allows users to display 3D models of bones and calculate their density. The software is used for the fast, safe and efficient design of prostheses for implant work.

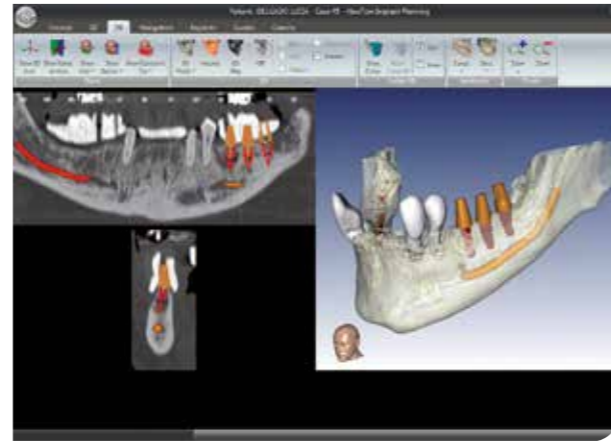

## Measurements and information

Implant operations can be planned easily by controlling the position of the mandibular canal and accurately measuring bone size and density.

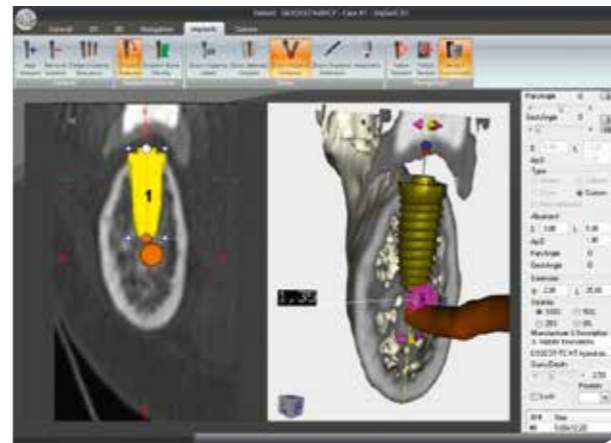

### AVAILABLE FORMATS

With NIP it's possible to work with axial images saved in the DICOM 3.0 format or the NNT format, used on all NewTom devices.

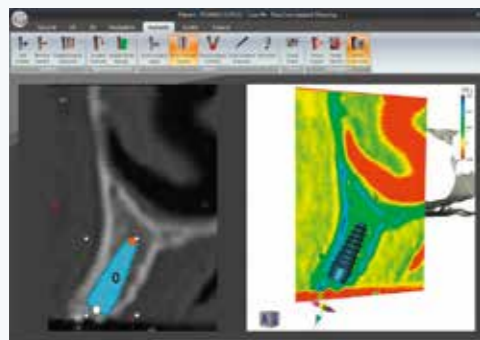

### 2D & 3D

The software generates 3D panoramic images, cross sections and bone models by reading the axial slices. To make surgery easier, all the patient's key anatomical aspects are identified: the exact position of the implant, any collision points and numerous other clinical factors.

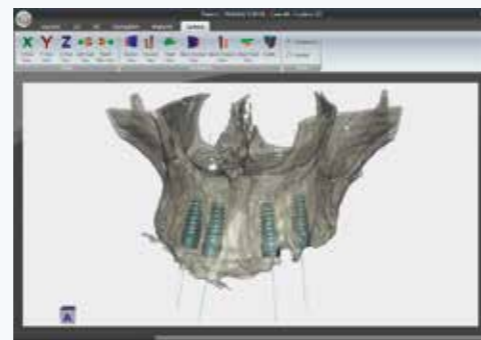

# CINEX : DYNAMIC IMAGES

NewTom VGi evo introduces the CineX function, characterized by the dynamic acquisition of a sequence of X-ray images that are stored as video; this allows for the investigation of moving internal anatomical structures. This function, active with the 19x17 cm on-patient FOV, can be used to study swallowing and saliva ducts, examine the temporomandibular joint disc with a contrast agent or assess vertebral extension.

A dedicated software menu allows users to:

- Select the acquisition position (AP or LL);
- Select the acquisition time;
- Check alignment of the area of interest using a scout image.

Once acquired, the video can be viewed in NNT or exported for display with third-party software.

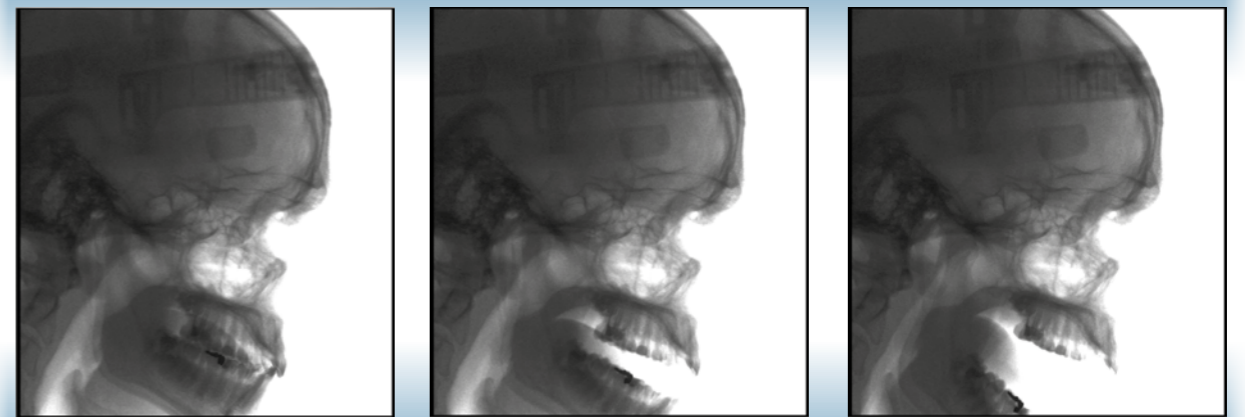

## A useful communication tool

All software-generated images can be used to communicate more effectively with patients (in compliance with regulations concerning informed consent).

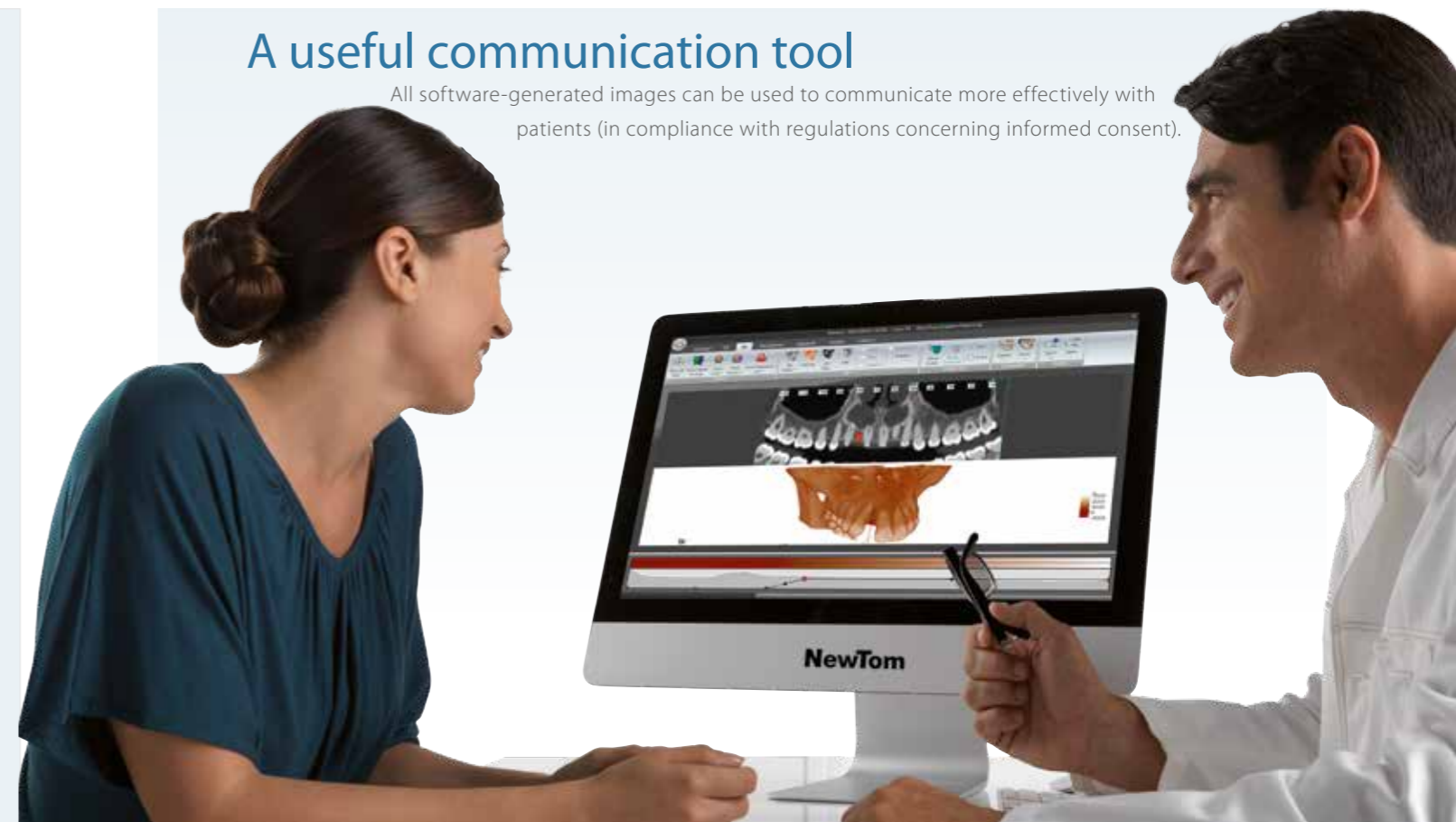

## CASE STUDIES

### Implantology

Cone Beam 3D is one of the most effective tools available for evaluating implant sites. 3D images can identify potential pathologies and structural abnormalities with unprecedented accuracy. The availability of such images provides vital information concerning the choice of implant to be used, the implant placement site, appropriate implant width and depth, and aspects such as the speed of the osseointegration process or rejection.

### Endodontics-Periodontics

To carry out procedures such as fractured tooth restoration, mandibular canal therapy or treatment of tissues adjoining a tooth, endodontic and periodontic specialists need imagery that lets them identify every possible detail inside the treated zone, determine the exact pathology and accurately plan effective treatment.

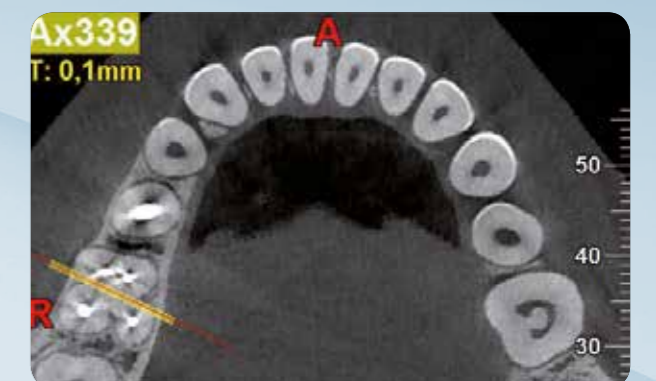
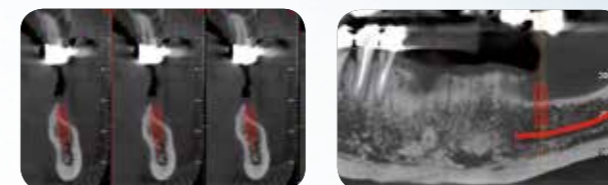
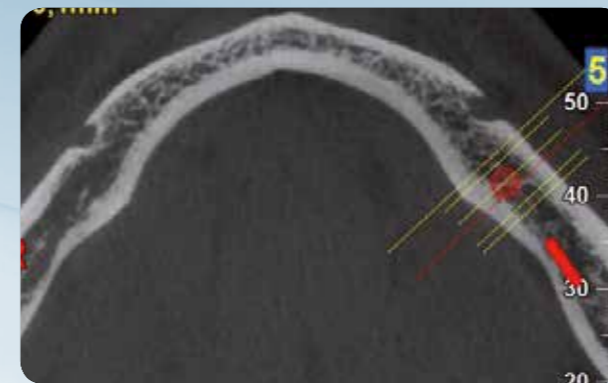

## TMJ

NewTom takes imaging of the temporomandibular joint to a whole new level.

Sagittal and coronal slices provide optimal imaging of the joint zone and allow identification of any pathology.

The attainable 3D images offer extremely high-quality, accurate anatomical representation of both the TMJ and the cervical zone.

Panoramic images, suitable for initial screening, provide important orthodontic information such as the difference between the height of the condyle and that of the mandibular ramus, or information on other dental pathologies.

## Oral and maxillofacial surgery

This discipline concerns the correction of several hard and soft tissue pathologies in the maxillofacial zone. A scan carried out with NewTom devices accurately shows characteristics such as the presence of teeth or fractures, bone density and height, or root shape and tilt.

In the case of post-operative scans, the presence of metallic elements does not affect image quality. On the contrary, because of the low X-ray exposure the scattering effect is almost nonexistent and the scanned anatomical structures are displayed clearly.

## Orthodontics

When carrying out orthodontic treatment, whether for aesthetic purposes or to cure more serious pathologies, Cone Beam X-ray technology with 3D image acquisition can produce a full array of extremely useful images (panoramic, telerradiography and 3D).

3D imaging provides a complete picture of the scanned area and also allows manipulation of both the angle and thickness of the reconstructed image.

## ENT

A single scan provides a clear view of all the airways, the structure of the ear, the nasal sinuses and the petrous bone.

Most examinations made using conventional CAT machines can also be made with NewTom, which provides more detailed images and, thanks to the use of suitable X-ray exposure parameters, prevents patient dosage overestimation.

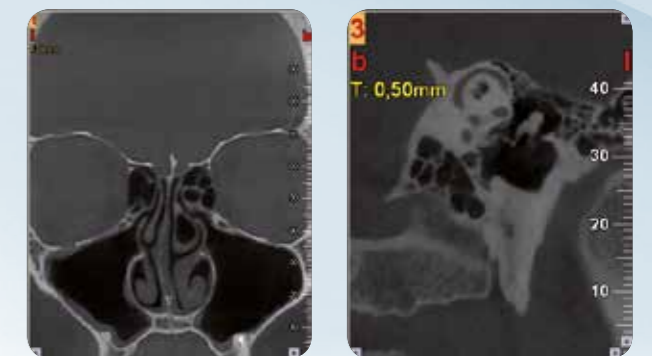
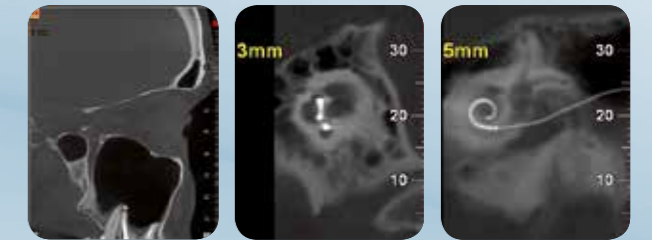
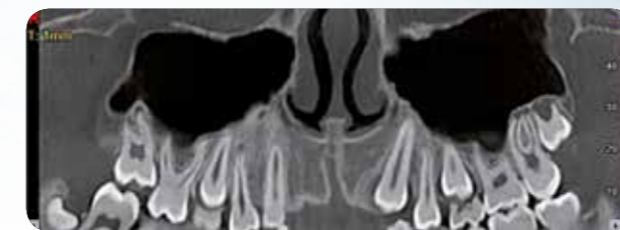
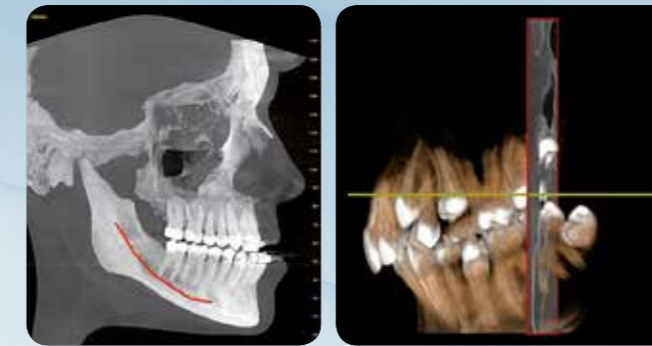
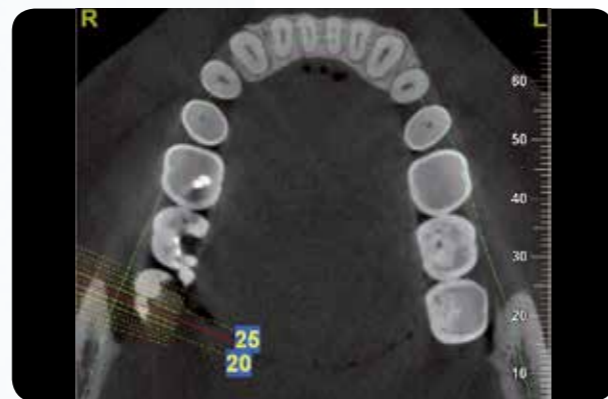
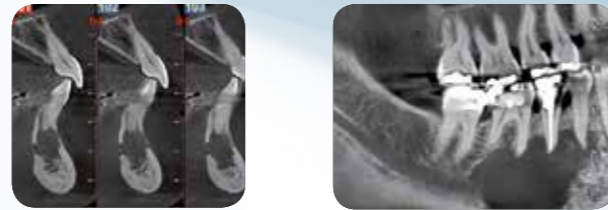
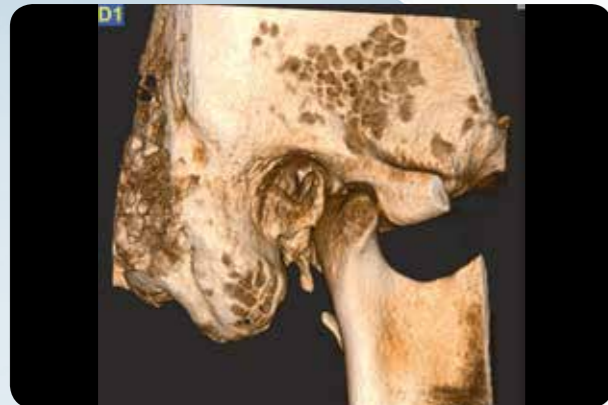

# TECHNICAL SPECIFICATIONS

X-Ray Source	High frequency generator, rotating-anode X-ray tube
Focal spot	0.3 mm
Exposure Control	SafeBeam™ to reduce exposure according to patient build
Sensor	Amorphous silicon flat panel
Grey levels	16-bit
3D scan time	15s (typical)
3D emission time	0.9s ÷ 4.3s
3D image acquisition	Single scan and Cone Beam technology

Available FOV DxH	Selectable 3D scan modes			
	Standard	HiRes	Eco	Boosted
24 x 19 cm - 9.45 x 7.48 in	•		•	•
16 x 16 cm - 6.30 x 6.30 in	•		•	•
15 x 12 cm - 5.90 x 4.72 in	•		•	•
15 x 5 cm - 5.90 x 1.97 in	•	•	•	•
12 x 8 cm - 4.72 x 3.15 in	•	•	•	•
10 x 10 cm - 3.94 x 3.94 in	•	•	•	•
10 x 5 cm - 3.94 x 1.97 in	•	•	•	•
8 x 8 cm - 3.15 x 3.15 in	•	•	•	•
8 x 5 cm - 3.15 x 1.97 in	•	•	•	•
5 x 5 cm - 1.97 x 1.97 in	•	•	•	•

Selectable voxel size - Standard 200 ÷ 300 µm

Selectable voxel size - HiRes 100 ÷ 150 µm

Reconstruction time Less than a minute

Sharp 2D image acquisition Panoramic and AP/PA/LL cephalometric images. Emission time 2.4s

CineX image acquisition Serial X-rays 1-36s, field of view 17x19 cm (WxH)

Patient positioning Standing, sitting or in wheelchair

Weight Scan unit 377 kg (831 lb), control box 95 kg (209 lb)

Software NNT

Power supply 15A @ 100/115V~, 12.5A @ 200V~, 10A @ 220/230/240V~, 50/60Hz

Specifications subject to change without prior notice.

# MAIN CONFIGURATION

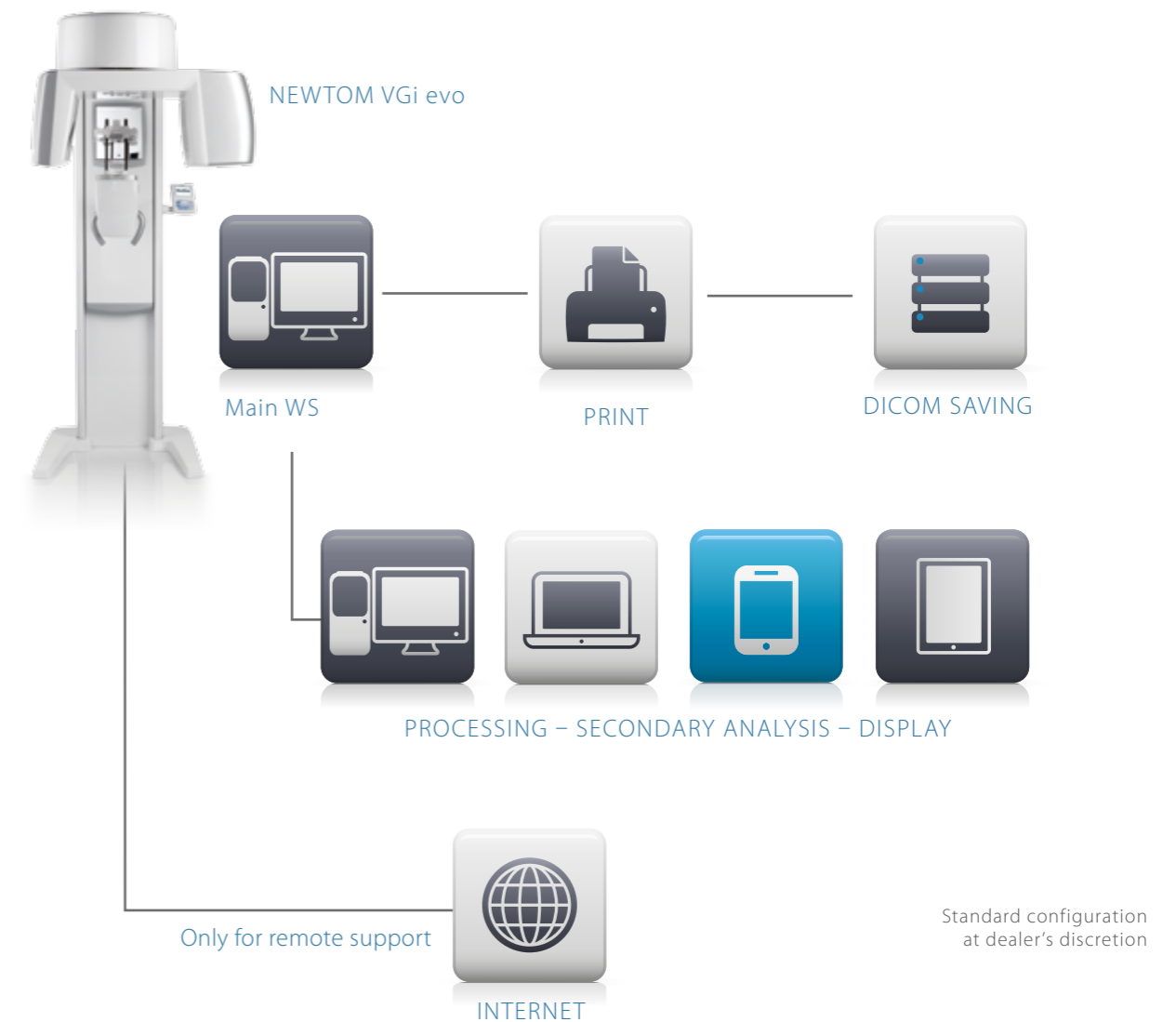

Dimensions in centimeters  
(dimensions in inches)

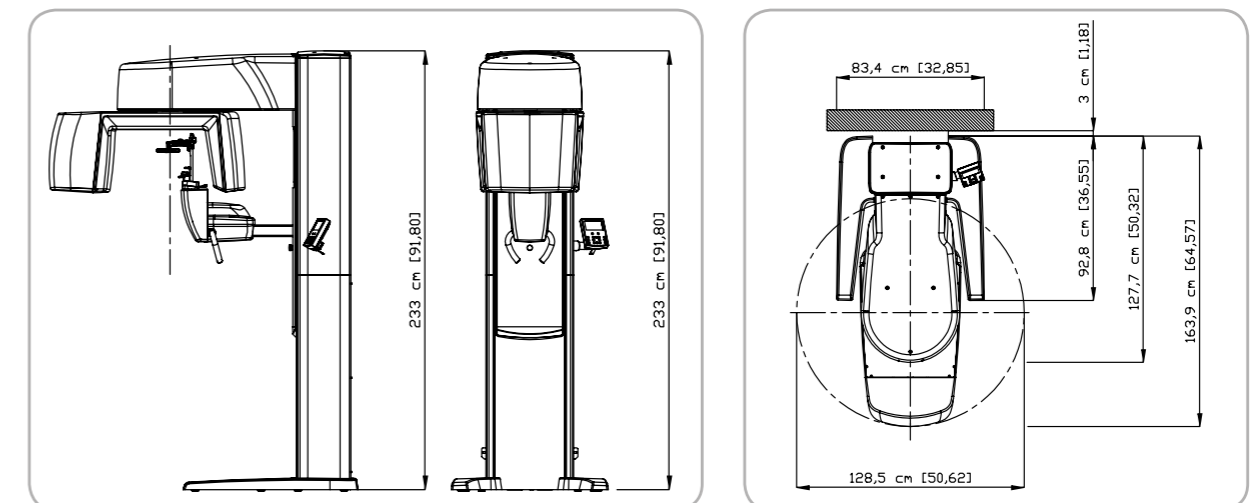

CE  
0051

Available on the  
**App Store**